

Guideline for Rescue Forces

Vehicles with Alternative Drive

hybrid



g-tron



e-tron



Legal Note:

This guideline has been prepared exclusively for rescue forces which have received a special training in the area of the technical assistance after traffic accidents and thus in the area of the activities described in this guide.

The specifications and the special equipment of Audi vehicles as well as the vehicle offered by the AUDI AG are continuously subject to possible change. For this, Audi expressly reserves adaptations and amendments of this document at any time.

Please observe: The information included in this guide are neither intended for final customers nor for workshops or dealers. Final customers can take detailed information about the functions of their vehicle as well as important safety notes about vehicle and passenger safety from the on-board documentation of their respective vehicles. Workshops and dealers receive repair information from the sources known to them.

Copyright

This document is subject to the copyright of the AUDI AG, Ingolstadt. Any duplication, distribution, storage, conveyance, transmission, reproduction or transfer of the contents is expressly forbidden without the written permission of the AUDI AG.

Contents

Alternative Drives

Preface	4
---------	---

Hybrid and electric drive (hybrid & e-tron)

Classification of electrification variants at Audi	6
Vehicle identification – hybrid and electric vehicles	7
Technical fundamentals	8
High-voltage safety concept	16
Notes for the rescue work	19

Natural gas drive (g-tron)

Vehicle identification – Natural gas vehicles	28
Technical fundamentals	29
Safety devices	33
Notes for the rescue work	36

Alternative Drives

Preface

Rescue forces study alternative drives on a world-wide scale, due to the availability of different drive concepts and the increasing number of vehicle with alternative drives. This applies to the general processes and procedures of rescue activities after traffic accidents, but also to the knowledge about the drive concepts themselves.

In the different countries of the world, the processes and procedures are normally regulated by service regulations or guidelines set up by legislation or by the rescue organisations themselves. If any notes on procedures are given in the present rescue guide, these must be exclusively understood as suggestions.

The main objective of the rescue guideline is to familiarise rescue forces with the drive concepts. Apart from the general presentation of the technology, main focuses are the identification and the safety concepts of the different technologies.

General information to vehicles can be taken from the General Guide for rescue forces.

Vehicle-specific information can be taken from the rescue data sheets (sometimes also called "Rescue Cards").

You can find these documents in German and English on <http://www.audi.de/rettungsleitfaden>.

Hybrid and electric drive (hybrid & e-tron)















Classification of electrification variants at Audi

There are different concepts for hybrid and electric vehicles. They differentiate with respect to the primary source of energy, the voltage, the type of driving machine, and the electric driving range.

A differentiation is made between:



- ▶ Mild-Hybrid Electric Vehicle (MHEV)
- ▶ Full-Hybrid Electric Vehicle (HEV)
- ▶ Plug-In-Hybrid Electric Vehicle (PHEV)
- ▶ Electric Range Extender Vehicle (EREV)
- ▶ Battery Electric Vehicle (BEV)

The table shows the different electrification concepts.

	Mild-Hybrid	Full-Hybrid	Plug-In-Hybrid	EREV	BEV
Voltage	120 – 130 V	200 – 270 V	300 – 450 V	300 – 450 V	300 – 450 V
Electric machine	10 – 15 kW	20 – 50 kW	60 – 70 kW	60 – 200+ kW	60 – 200+ kW
Electric driving range		approx. 3 km	approx. 50 km e-tron	approx. 50 – 200 km e-tron	> 200 km e-tron
Source of energy	 	 	  	  	 
Examples		Q5 hybrid quattro A6 hybrid A8 hybrid	A3 Sportback e-tron	A1 e-tron	R8 e-tron

r001_006

Legend for energy sources

Symbol	Designation
	Traditional fuels as e. g. petrol and diesel
	Battery operation
	Battery operation with charging possibility via socket

Vehicle identification – hybrid and electric vehicles

Vehicles with alternative drive concepts can be identified according to different distinguishing characteristics.

Having this knowledge, rescue forces can adapt their activities to the corresponding technology of the vehicles involved in an accident.

Distinguishing characteristics – hybrid and electric vehicles (examples)

Logotypes on the car body exterior

The Audi Full-Hybrid models have the name "hybrid". Vehicles offering an external charging possibility, e. g. via a socket, have the name "e-tron".

In this example, the logotype is on the boot lid; the logotype on the mudguard is identical.

The logotypes are different among the vehicle manufacturers, and can partially be cancelled in the orders. It is also possible that the vehicle owners remove them.



r001_101

r001_085

Dashboard insert with power meter



r001_007

Logotype on door sill strips



r001_086



r001_008

Logotype on the design cover in the engine compartment and orange-coloured high voltage cable

Charging socket

Please observe:

Not every hybrid vehicle variant is equipped with a charging socket.



r001_048

Technical fundamentals

Introduction

A hybrid vehicle is driven by a combination of a combustion engine and an electric machine supplied with current from a high-voltage battery.

The electric machine supports the combustion engine in acceleration phases and is used as a generator in braking phases in order to charge the high-voltage battery (recuperation). In Full-Hybrid (HEV) and Plug-In-Hybrid (PHEV) vehicles, it furthermore allows purely electromotive driving (E-driving).

The high-voltage battery is charged by the electric machine working as a generator; in case of Plug-In-Hybrid vehicles it can also be charged via the charging socket.

An electric vehicle is exclusively driven by an electric machine. Electric vehicles having – apart from the battery – an additional combustion engine which is used for charging the battery, are called Electric Range Extender Vehicles (EREV).

Audi A3 Sportback e-tron as example for a hybrid vehicle

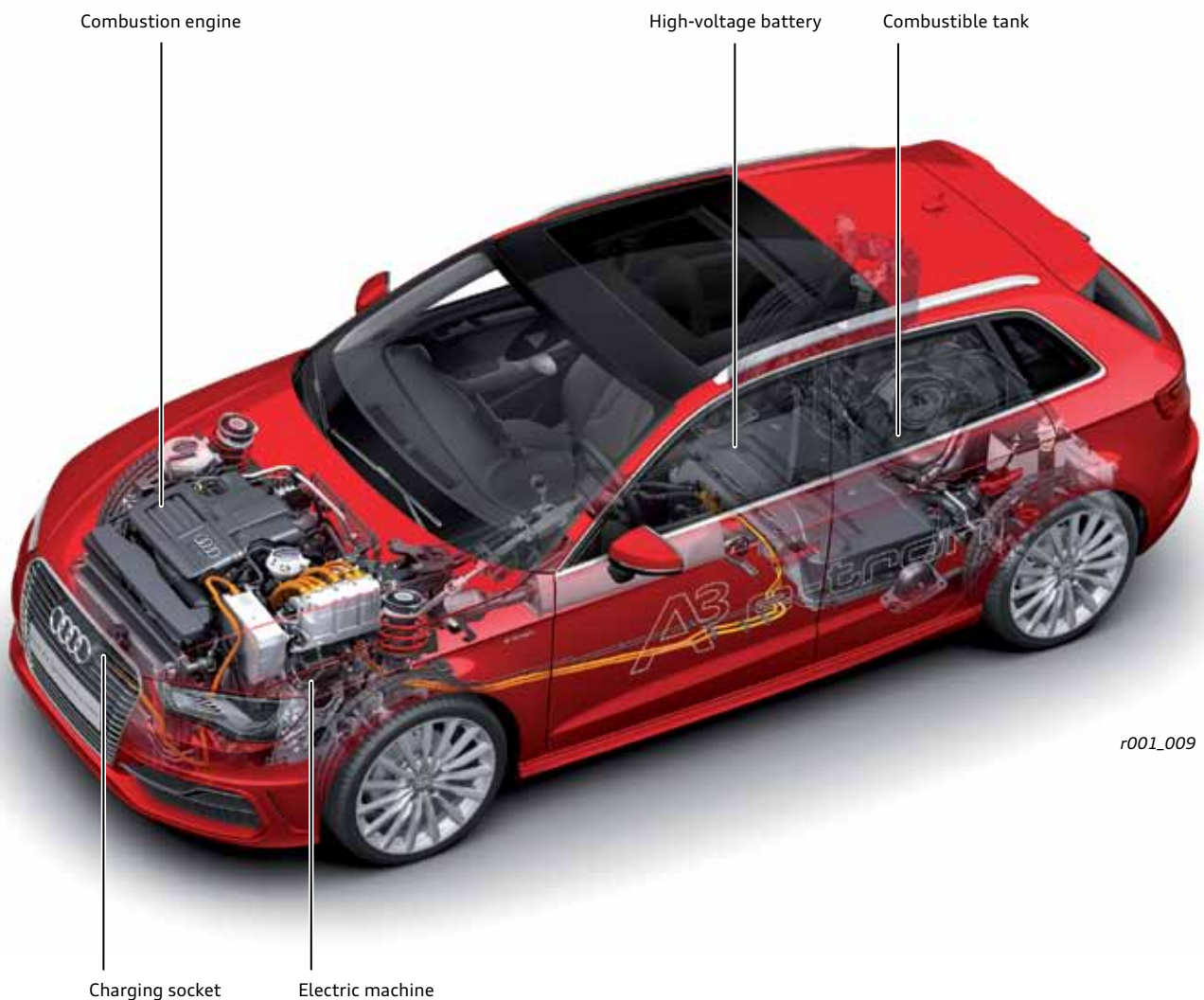

r001_009

The combustion engine exclusively serves for charging the battery and has no connection to the drive train. Electric vehicles having a battery as the only source of energy are called Battery Electric Vehicles (BEV).

Other auxiliary units as e. g. the air conditioning compressor are supplied from the high-voltage battery due to their high energy consumption. Thus, these auxiliary units count among the high-voltage components, too.

As only electric current is available as the source of energy for electric driving, also other components as e. g. the coolant pump are driven electrically and supplied with current from the 12 V on-board network.

Audi A3 Sportback e-tron – Overview of hybrid components

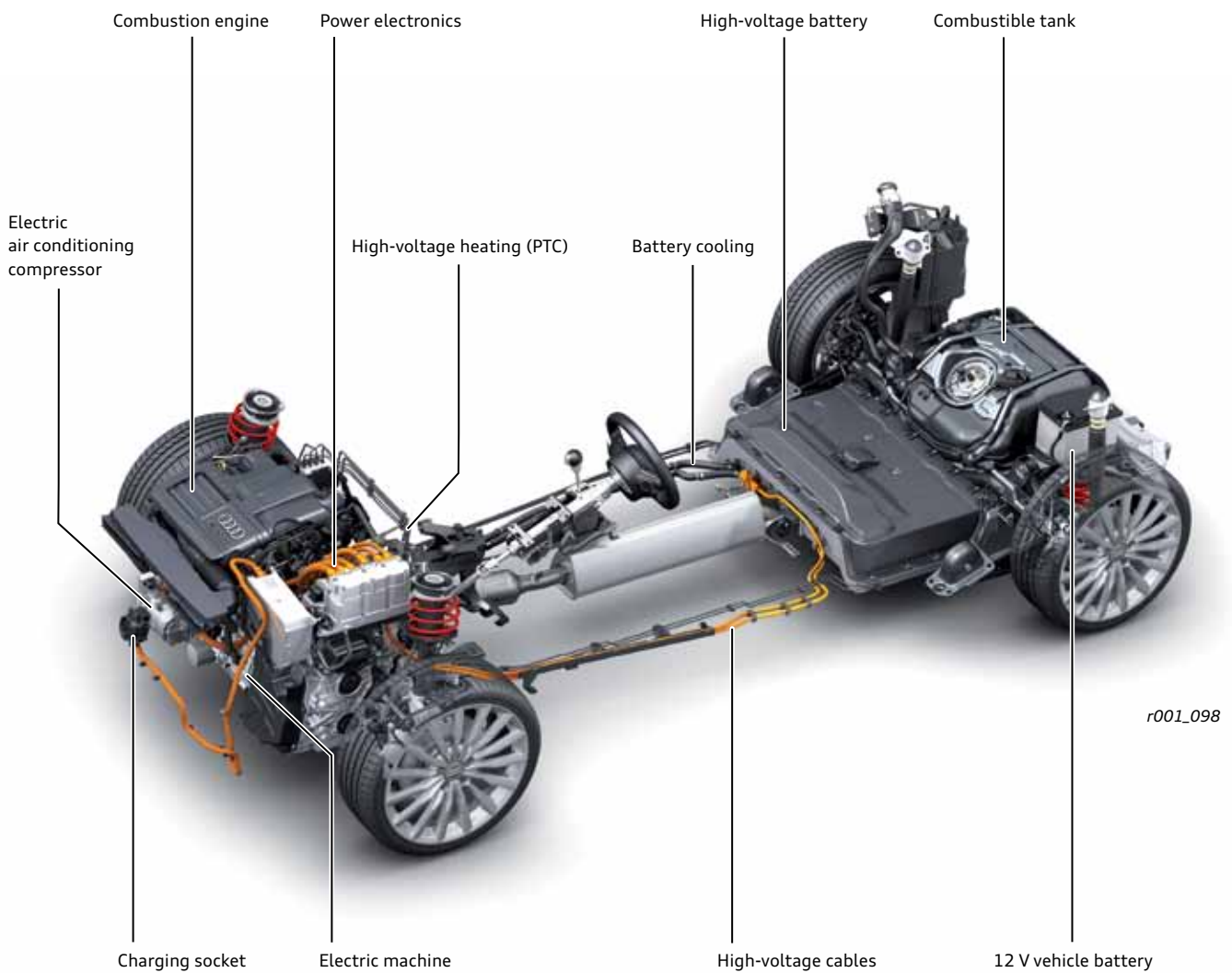

Operating statuses

Different characteristic operating statuses are differentiated in the drive of a hybrid and electric vehicle.

In Audi vehicles, the different operating statuses are displayed in the power meter; they can furthermore be indicated graphically in the display of the instrument cluster.

The displays of the Audi Q5 hybrid quattro shall serve as example in the following.

For battery vehicles, the operating statuses with combustion engines are omitted.

Display in the dashboard insert



r001_040

Hybrid system ready for operation "Hybrid Ready"

The hybrid system is ready for operation.

 Even if the vehicle does not emit any noises, it is ready for operation in this status and can start to drive! (see also "Notes for the rescue work")



r001_010

Drive only with electric machine

The symbol for the high-voltage battery and the green arrows pointing away from the wheels indicate that the vehicle is driven by the high-voltage battery and the electric driving motor.



r001_011

Drive only with combustion engine

The symbol for the combustion engine and the yellow arrows pointing away from the wheels indicate that the vehicle is driven by the combustion engine.



r001_012

Drive with electric machine and combustion engine

The symbol for the combustion engine, the high-voltage battery and the green/yellow arrows pointing away from the wheels indicate that the vehicle is driven by the combustion engine, the high-voltage battery and the electric driving motor.



r001_013

Recuperation in overrun phase

The symbol for the high-voltage battery and the green arrows pointing towards the wheels indicate that recuperation is taking place and that the high-voltage battery is charged.



r001_014

Standing vehicle and combustion engine

The symbol for the combustion engine and the high-voltage battery indicate that the combustion engine is running and the high-voltage battery is charged.



r001_015

High-voltage technology

In vehicle technology, the following voltage ranges are designated "high-voltage":

- ▶ more than 60 V for direct current (DC) and
- ▶ more than 30 V for alternating current (AC)

Apart from the high-voltage battery, the electric machine and the high-voltage distribution and control unit, the so-called power electronics, also auxiliary units are driven with high-voltage current.

The following chapter highlights the following high-voltage components.

- ▶ High-voltage battery
- ▶ Power electronics
- ▶ E-machine
- ▶ Auxiliary units as e. g. high-voltage air conditioning compressor and PTC auxiliary heater
- ▶ High-voltage cables and connectors

The image shows a principle sketch of a high-voltage system.

Overview of high-voltage system

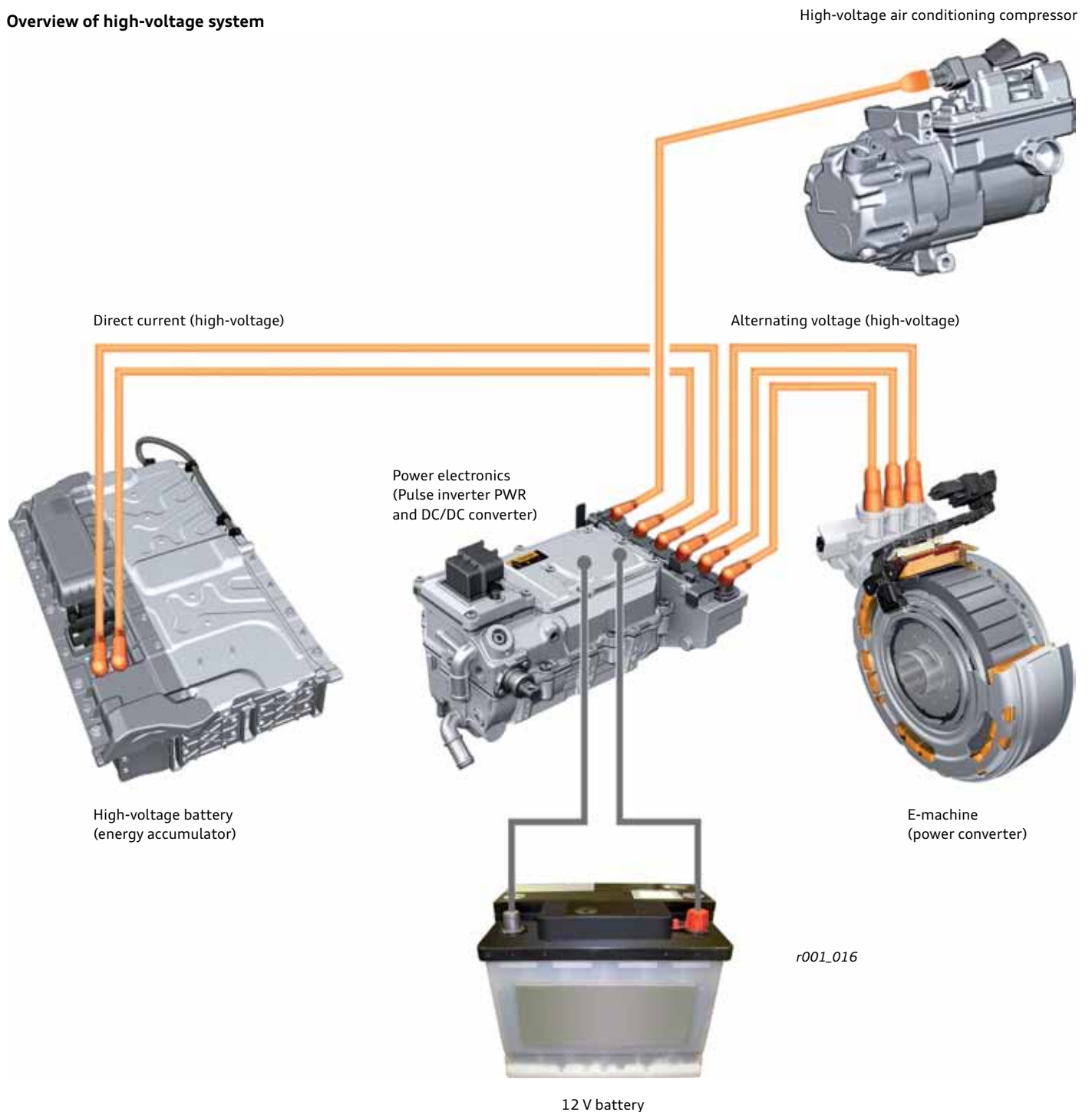

High-voltage battery

The high-voltage batteries used by Audi are Li-ion batteries. The high-voltage battery is arranged in vehicle areas with low probability of deformation in case of a crash, hit only in rare cases. It consists of modules of battery cells connected in series. Several modules are installed, along with the peripherals, in a metal casing to the vehicle.

High-voltage batteries are cooled during operation. The cooling system can be designed as air-cooled or liquid-cooled system. A gas vent is installed to the casing in order to guide harmful gases to an outlet below the vehicle in case of a defective battery cell.

The control unit for the battery regulation is integrated into the high-voltage battery. This control unit connected the high-voltage battery to the other elements of the high-voltage system. The control unit includes safety systems for the high-voltage systems and the high-voltage battery monitoring device. Both battery poles are equipped with protection relays (contactors) which are closed for the operation of the high-voltage system. In case of an accident with airbag or belt tensioner activation, these protection relays are opened and the high-voltage system outside the battery discharges.

Apart from the high-voltage battery, hybrid and electric vehicles are equipped with the common 12 V battery system with one or more batteries.

Air-cooled high-voltage battery (example: Audi A6 hybrid)

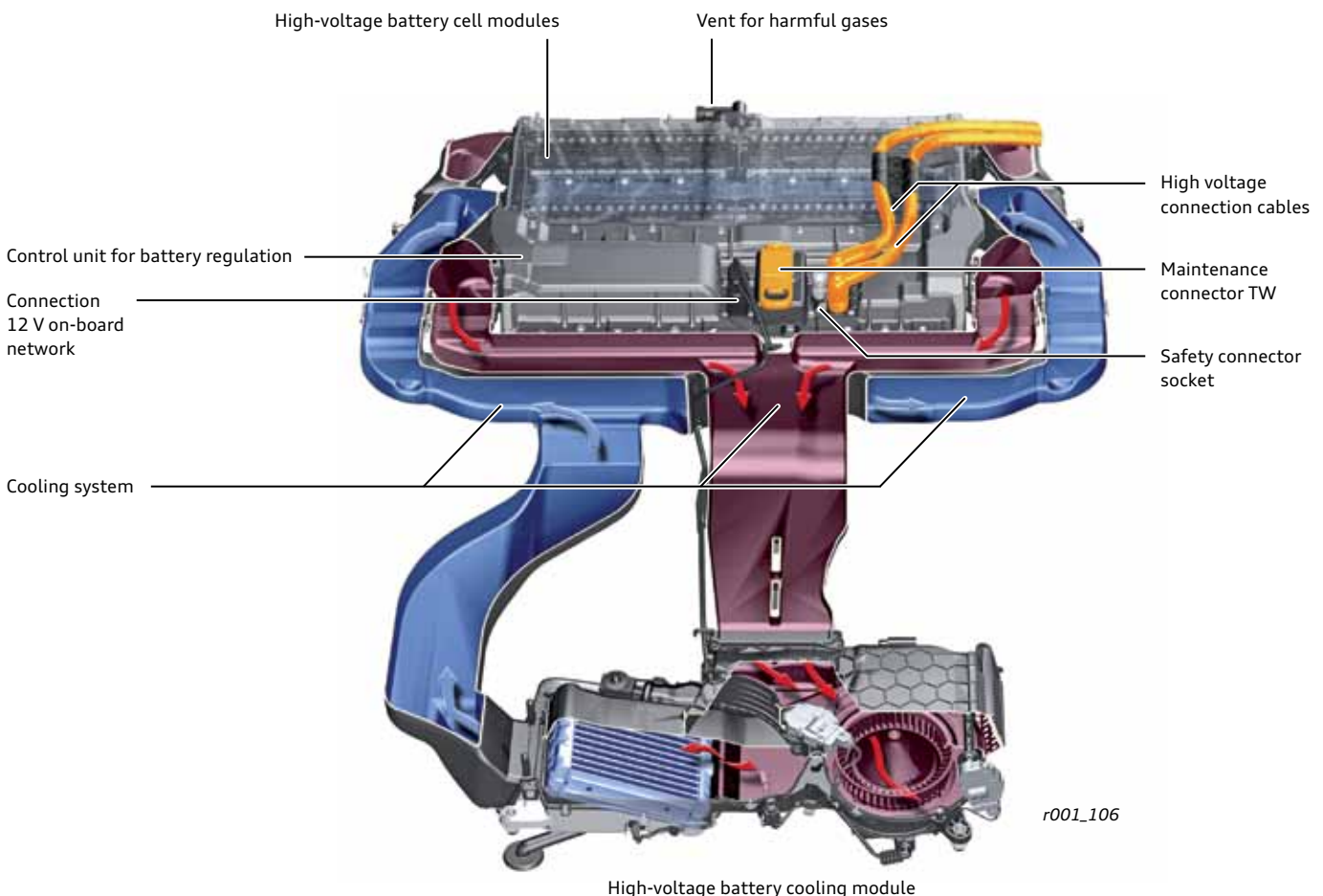

Liquid-cooled high-voltage battery
(example: Audi A3 Sportback e-tron)

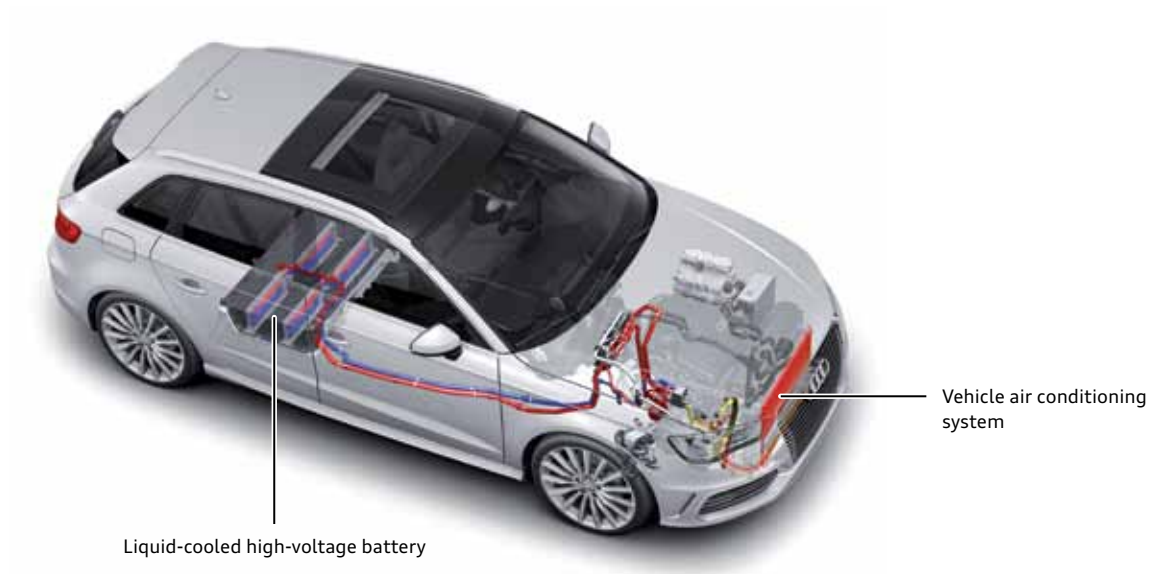

r001_103

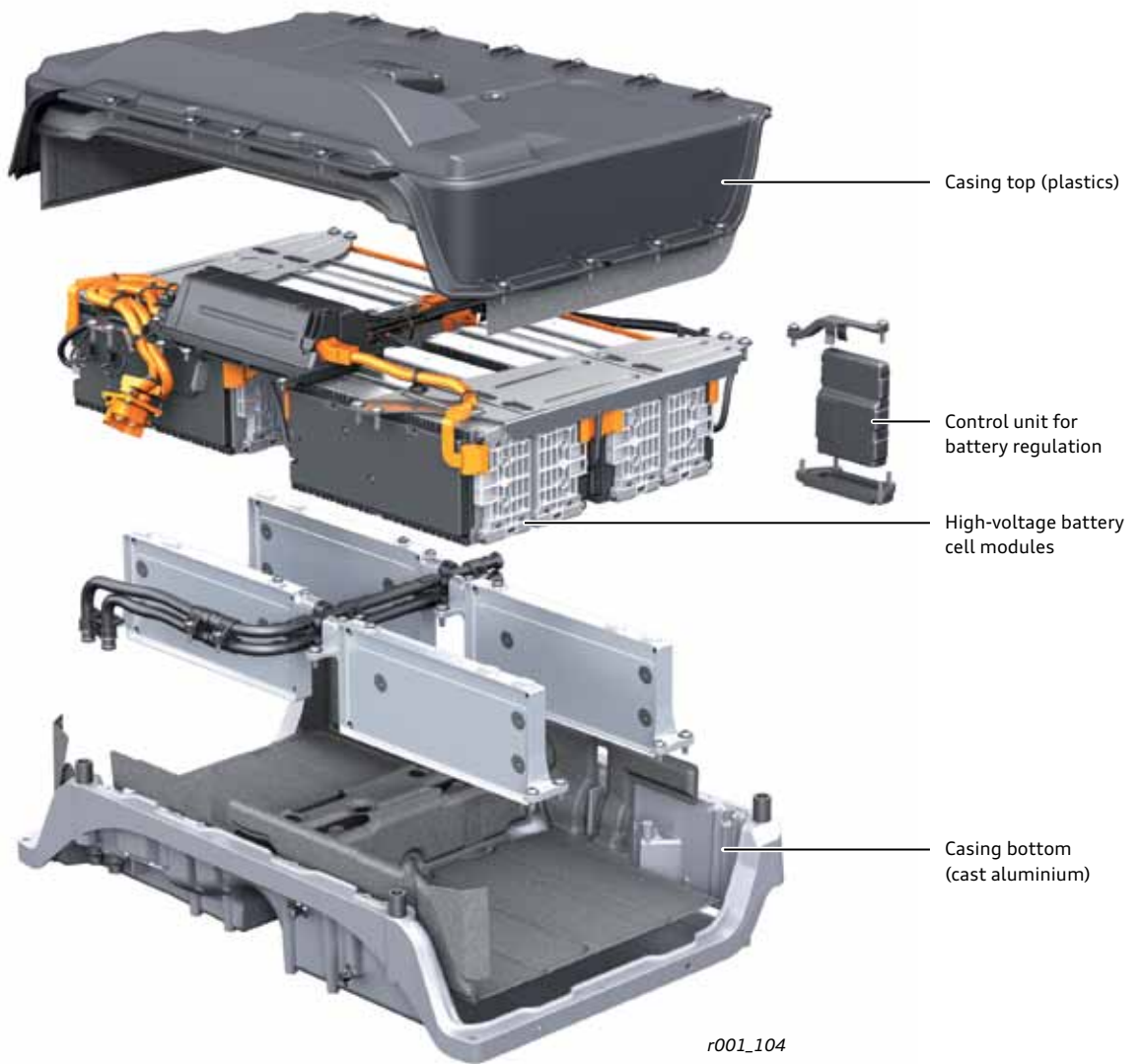

r001_104

High-voltage cables and connectors

The cables with the associated high-voltage connectors connect the high-voltage battery to the other high-voltage components in the engine compartment, as well as the high-voltage components to each other as e. g.

- ▶ Power electronics
- ▶ Electric machine
- ▶ Air-conditioning compressor

The high-voltage cables are usually installed outside the passenger compartment, i. e. they are below the vehicle bottom or in the engine compartment.

All high-voltage cables resp. the plugged high-voltage connections have an orange coloured insulation in the visible areas. Furthermore, additional covers and hoses protect the high-voltage cables against damage. In contrast to the 12 V on-board network, the high-voltage system does not have electrical potential to vehicle earth.

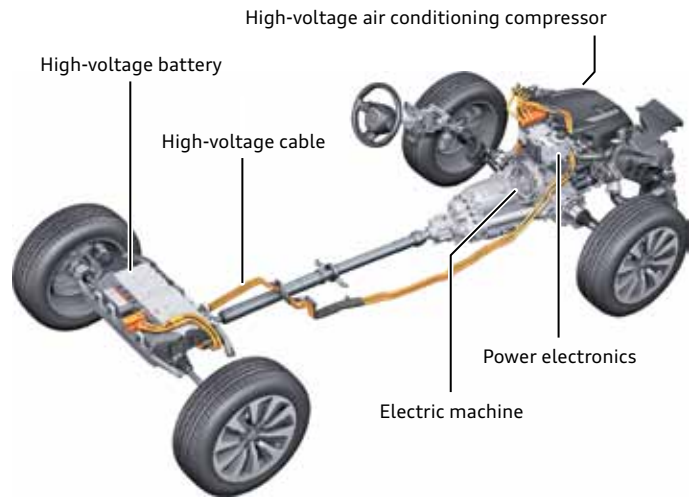

r001_019

Example: Audi Q5 hybrid quattro

Power electronics

The power electronics system is the distributor and energy converter of the electric drive. According to operating status, it converts direct voltage from the high-voltage battery to alternating voltage for the electric machine, or vice versa.

Furthermore, the power electronics system converts the high voltage to a 12 V direct voltage for the 12 V on-board network (and partially vice versa).

The auxiliary units operated with high voltage are also supplied by the power electronics system.

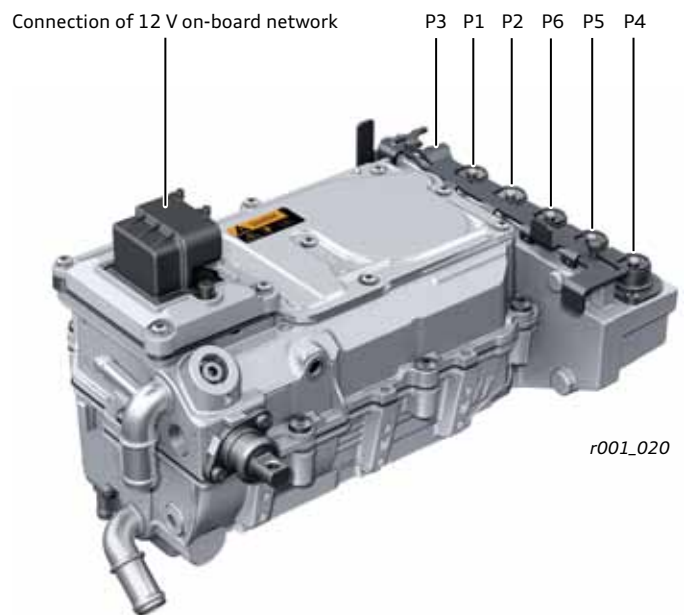

r001_020

Example: Audi A6 hybrid and A8 hybrid

- P1 Connection – high-voltage battery (HV plus)
- P2 Connection – high-voltage battery (HV minus)
- P3 Connection – air conditioning compressor
- P4 Connection – drive motor for electric drive (U)
- P5 Connection – drive motor for electric drive (V)
- P6 Connection – drive motor for electric drive (W)

Electric machine (E-machine)

In Audi vehicles, the electric machine, also abbreviated E-machine, is located between the combustion engine and the transmission. The electric machine is operated with alternating current resp. three-phase current. For this, the power electronics system converts the direct voltage of the high-voltage battery to an alternating voltage with three phases.

Apart from the actual drive of hybrid vehicles, the E-machine also serves for starting the combustion engine, and in generator operation for charging the high-voltage battery. The operating status of the E-machine is controlled by the engine control unit and the power electronics system in order to ensure highest efficiency and performance of the drive. If e. g. the motor control unit detects that the power of the E-motor is sufficient for driving the vehicle, the combustion engine is switched off.

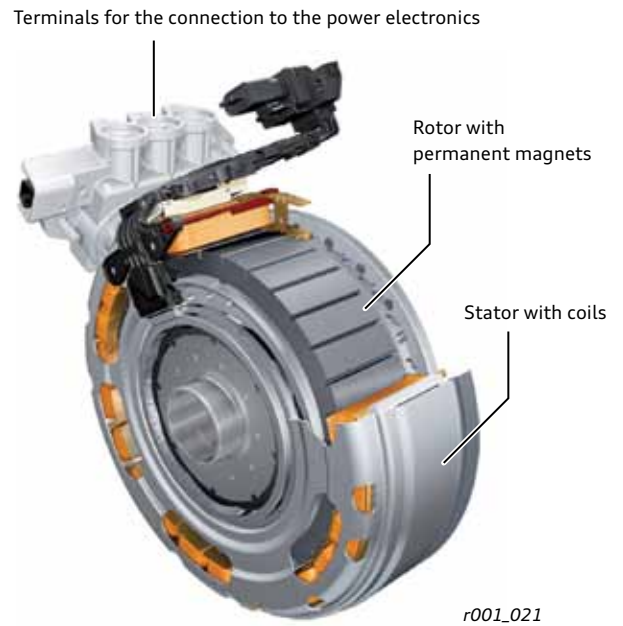

Example: Audi A6 hybrid

High-voltage air conditioning compressor

The electric air-conditioning compressor is integrated into the high-voltage system. A high-voltage cable connects it to the power electronics for the electric drive.

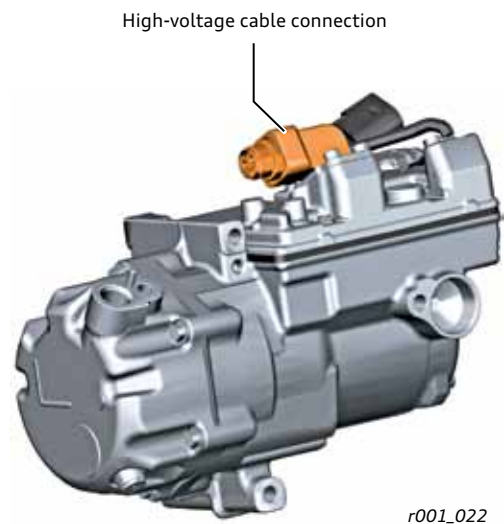

Example: Audi Q5 hybrid quattro

High-voltage heating

Another auxiliary unit, which can be designed as a high-voltage component, is the high-voltage heating. It generally works with the PTC technology (PTC = Positive Temperature Coefficient); thus, it is also called PTC auxiliary heating system. The heating has the function to heat up the coolant for the heating heat exchanger in the interior during electric driving operation.

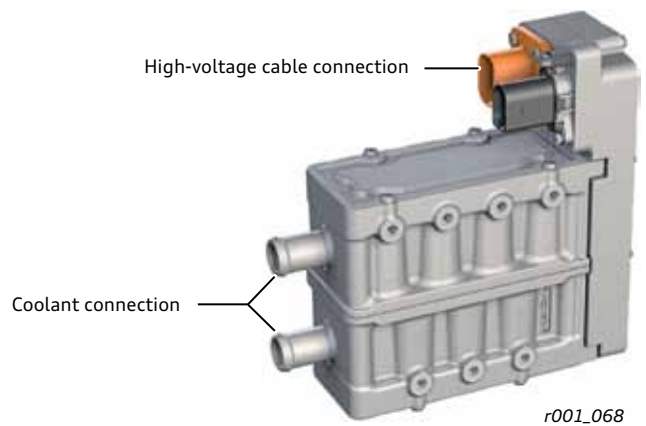

Example: Audi A3 Sportback e-tron

High-voltage safety concept

The electric components in the vehicle, as e. g. the power electronics the E-machine, the high-voltage battery and the auxiliary units as e. g. an electric air conditioning compressor, work in voltage ranges above 30 V alternating current and 60 V direct current. As this voltage is higher than the common on-board network voltage in traditional vehicles of 12 V, the designation "High-voltage" is used for this voltage range in vehicles.

In case of improper handling, the voltage in the high-voltage system poses a potential danger. Thus, there is a comprehensive safety concept for the vehicle. The following chapter explains the essential principles of the safety concept.



In case of improper handling of high-voltage components there is danger to life due to the high voltage and the possible flow of current through the human body.



There is still voltage in the high-voltage battery even after the deactivation of the high-voltage system. The high-voltage battery must neither be damaged nor opened – danger to life!



High-voltage cables must not be damaged or separated from the high-voltage system by non-qualified personnel. Danger to life in case of improper handling.



Only correspondingly qualified personnel may directly handle high-voltage components if this is necessary during any measures to be performed at the vehicle.

Galvanic separation

The high-voltage system is galvanically separated from vehicle earth. That means that there is no direct electric connection between the high voltage poles and the car body.

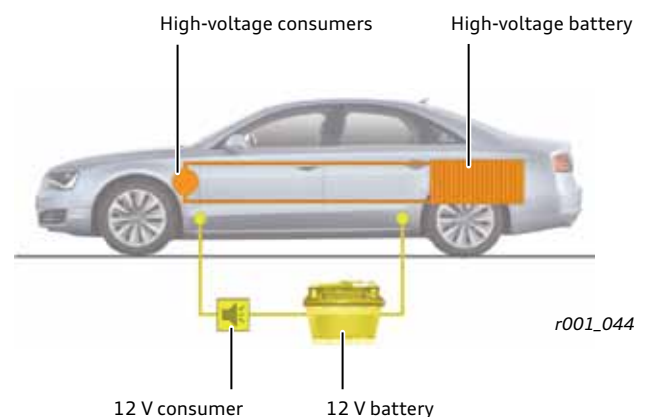

Touch protection

All connections (plugs, flange receptacles) at the high-voltage components of the vehicle are safe to touch.

High-voltage cables

All high-voltage cables have an orange coloured insulation in the visible areas. Furthermore, additional covers and hoses protect the high-voltage cables against damage.

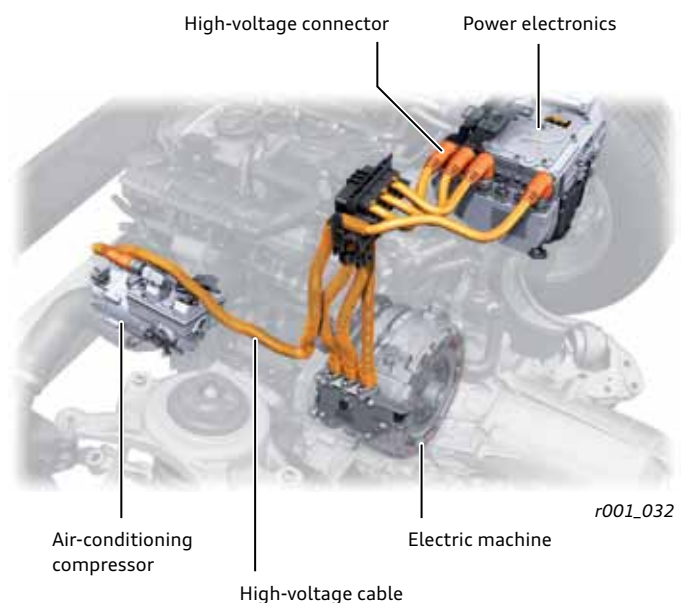

Warning labels

All high-voltage components (except for high-voltage cables) are marked with explicit warning stickers.

There are the following basic warning sticker types:

- ▶ Warning sticker with the word "Danger" on red ground

The warning stickers with the word "Danger" directly identify high-voltage components.



r001_025

- ▶ The high-voltage battery is identified by a bigger label with corresponding warning notes.



r001_023



r001_024

Short-circuit detection

A short-circuit detection/fuse is integrated in the battery system as an over-current protection; if it trips, the current flow will be interrupted.

Discharge of residual voltages

In case of an accident with airbag activation or after an unexpected malfunction the discharge circuit ensures that the high-voltage system is free from voltage after approx. 20 seconds.

Insulation monitoring

The insulation resistance of the high-voltage system is monitored in intervals in order to detect whether the high-voltage poles are separated from the car body.

Malfunctions are indicated with a warning message, the lighting of a yellow lamp in the combined unit, and an acoustic signal.

Disconnection in case of a crash

Both battery poles are equipped with protection relays (contactors) which are closed for the operation of the high-voltage system. In case of an accident with airbag or belt tensioner activation, the high-voltage battery receives a crash signal for opening the protection relays. The protection relays of the high-voltage battery open and the high-voltage system outside the battery discharges (see "Discharge of residual voltages"). The high-voltage connections of the high-voltage battery will then be free from voltage.

Beyond the automatic crash deactivation, the vehicle specific rescue data sheets of hybrid and electric vehicles contain information about how to deactivate the high-voltage system and the vehicle itself.

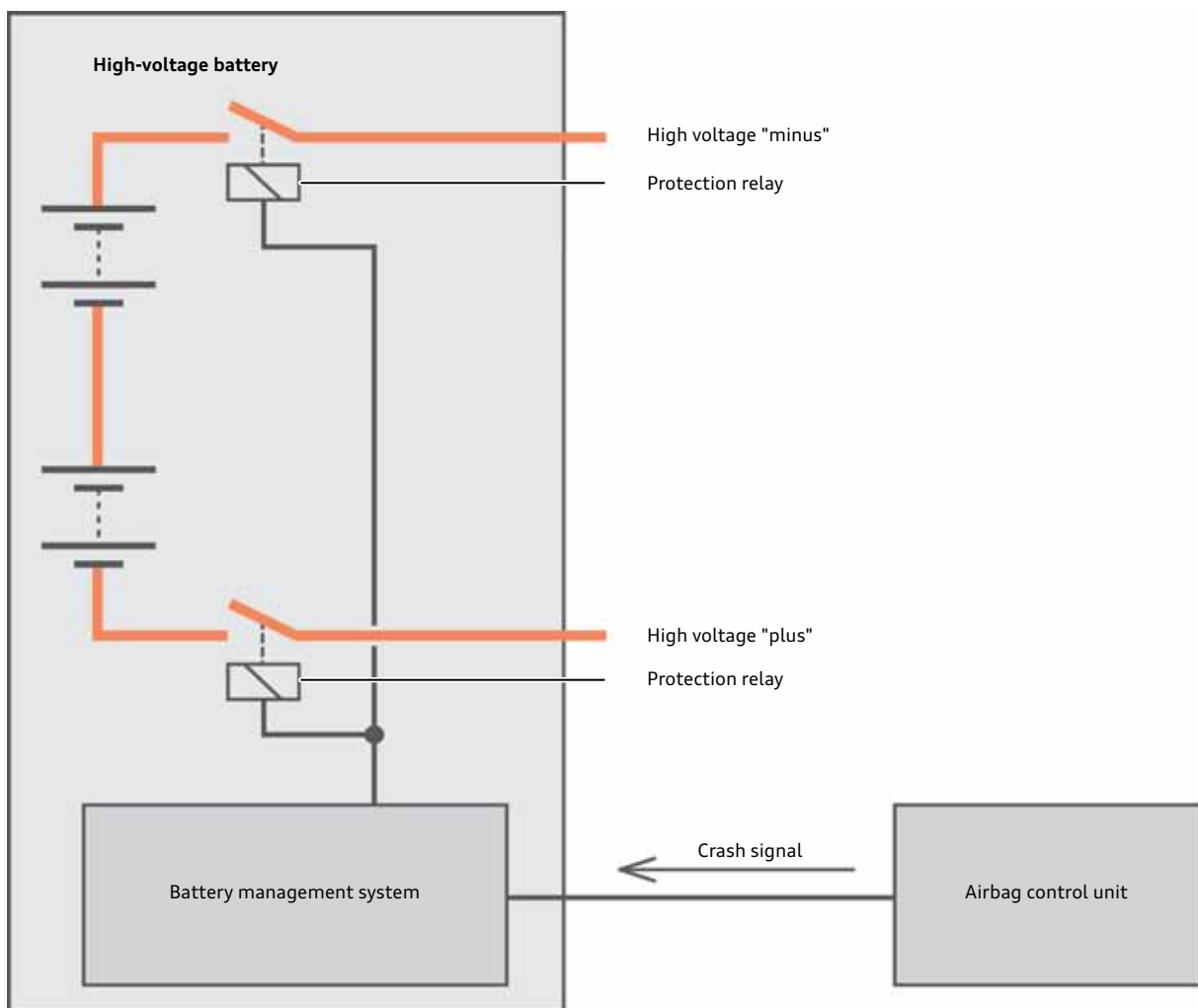

r001_056

Notes for the rescue work

Handling hybrid and electric vehicles is generally not more dangerous than handling petrol or diesel vehicles; however, it differs in some items.

Knowledge about these differences can be important for the rescue work after car accidents.

Readiness for operation

It can be difficult to determine the readiness for operation from the operating noises, because the electric machine is noiseless. The electric drive is active if the power meter in the instrument cluster shows READY.

Chapter "Technical assistance" describes how a hybrid or electric vehicle can be immobilised and deactivated.

As long as the big indicator display on the left of the power meter is not indicating "off" (e. g. on the position READY), an operation of the electric machine or with an automatically starting combustion engine can be expected.



r001_062

Technical assistance

The high-voltage safety concept, in particular the "shut-down in case of crash", normally ensures that the high voltage system does not pose any dangers after a traffic accident.

In case of an accident with airbag activation, the protection relays of the batteries are opened, so that the high-voltage connections of the battery system become free from voltage (see also chapter "Disconnection in case of a crash". A discharge circuit in the further high-voltage components insures that these become voltage-free after 20 seconds at the latest (see also chapter "Discharge of residual voltages").

The procedures of rescue forces are generally regulated by corresponding laws, regulations or guidelines.

The subsequent chapters generally highlight issues which could become significant during the technical assistance after accidents of vehicles with hybrid or electric drive.

Rescue data sheets

Vehicle specific peculiarities are described in the rescue data sheets.





The rescue data sheets for vehicles with alternative drive may contain additional information about the handling of the vehicle. In particular, in most cases the procedure for the deactivation of the vehicle can be taken from the rescue data sheets of these vehicles.

Apart from the indications normally included in the rescue data sheets of conventionally driven vehicles, the rescue data sheets for hybrid and electric vehicles indicate the position of the high-voltage battery, the cables between battery and engine compartment, and the devices for deactivating the high-voltage system.

In addition to schematic top and lateral view (on the first page) rescue data sheets may include further pages with the following sections:

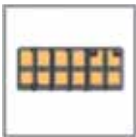
- ▶ Immobilising the vehicle
- ▶ Switching off the ignition
- ▶ Separating the charging cables
- ▶ Deactivation of the high-voltage system
- ▶ Separation of the 12 V battery/batteries

The symbols in the rescue data sheets applying in particular for hybrid and electric vehicles are:

Symbol	Designation	Symbol	Designation
	High-voltage battery		High-voltage cables and components
	High-voltage rescue separation point		Fuse box with fuse for high-voltage deactivation



The example on the following page shows the overall structure of rescue data sheet.

Example for a rescue data sheet

Sheet 1-4 of the rescue data sheets for the Audi A3 Sportback e-tron (status 05/2014)

Sheet 1

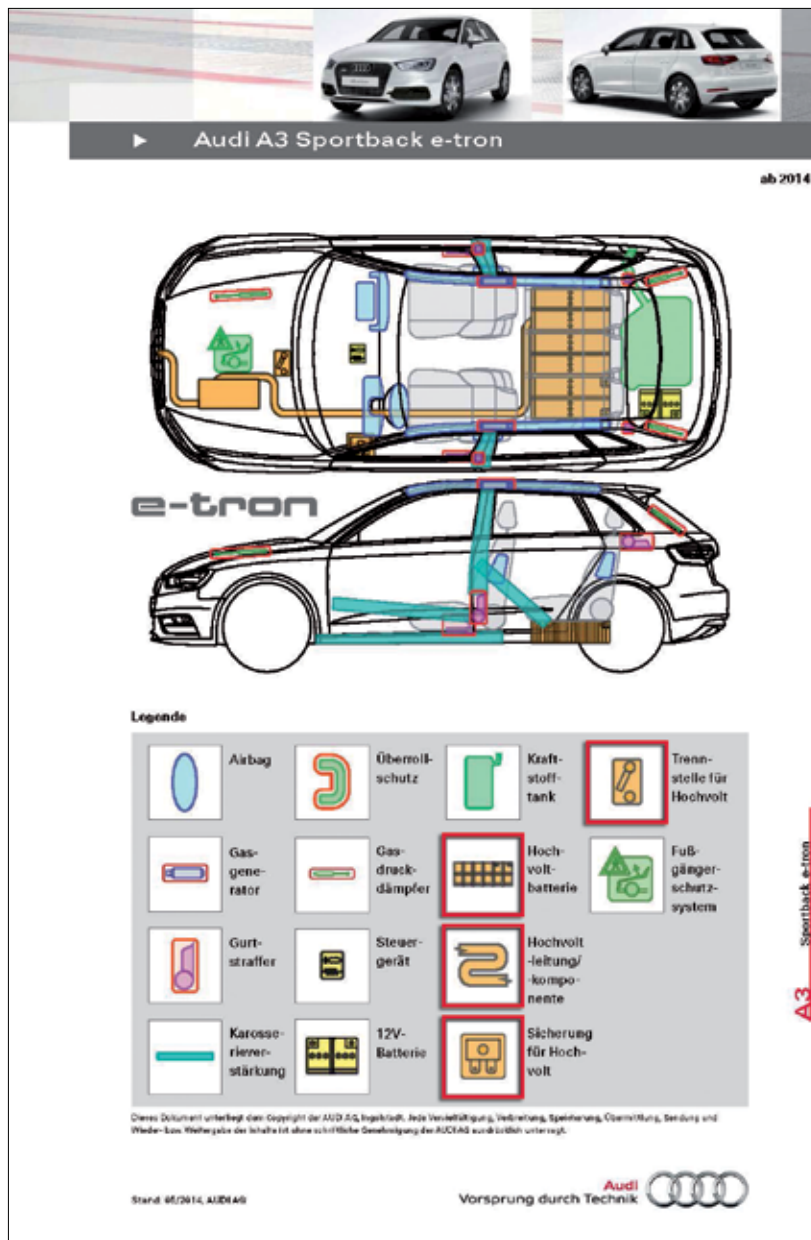

r001_034_1

 Symbols applying in particular for hybrid and electric vehicle

Sheet 2



r001_034_2

Sheet 3



r001_034_3

Sheet 4



r001_034_4

The rescue data sheets for Audi vehicles can be downloaded on the Audi homepage website under: <http://www.audi.de/rettungsleitfaden>

An overview of the sources of supply for rescue data sheets of all vehicle manufacturers can be found on the website of the German Association of the Automotive Industry (Verband der Automobilindustrie e. V.) (VDA): http://www.vda.de/de/arbeitsgebiete/rettungsleitfaeden_feuerwehr/

Immobilising the vehicle

According to the situation requirements, the vehicle must be stabilised by appropriate means (slings, chocks etc.).

The parking brake of the vehicle should be actuated.

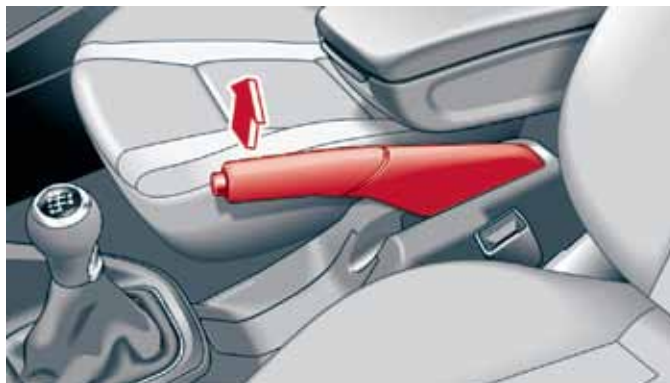

Parking brake

r001_042

Modern vehicles can be equipped with an electronic parking brake (electromechanical parking brake) instead of a manual parking brake (hand break). The electronic parking brake is normally located near or behind the gear/selector lever and is actuated by "pulling".



Electromechanical parking brake

r001_043

For vehicles with automatic transmission, the transmission should be set to position "P" (parking).



Setting the selector lever to position "P"

r001_038

Switching off the ignition

The ignition system of vehicles with ignition lock can be switched off by turning the ignition key towards the passengers "position 0".



Vehicle with ignition lock

r001_045

Vehicles with comfort key do not have a conventional ignition lock. The driver only needs to carry the vehicle key in a pocket. The key "START ENGINE STOP" switches the ignition on or off and starts or stops the engine.

When the ignition is switched on, the key "START ENGINE STOP" must be pressed once in order to switch the ignition off.



Key "START ENGINE STOP"

r001_046



Before you press the key "START ENGINE STOP" ensure that the clutch pedal (manual transmission) or break pedal (automatic transmission) is not pressed. Otherwise the engine will start!



r001_102

Separating the charging cables

If the vehicle connected to a charging pole is involved in an accident, the interruption of the charging process cannot be ensured.

It is recommended to ensure the interruption of the charging process by pulling the connector from the charging pole.

The following working steps are necessary in order to separate the charging cable from the vehicle:

1. Unlock the vehicle by the radio key or the central locking switch in the interior
2. Separate the charging cable from the vehicle



r001_095



r001_096



r001_097

Deactivation of the high-voltage system

The high-voltage system of Audi vehicles is deactivated automatically with the activation of the airbags.

Beyond this, the service rescue data sheets for hybrid and electric vehicles in many cases describe another possibility for deactivating the high-voltage system.

Service-Disconnect

Some vehicles are equipped with a so-called "Service-Disconnect" plug. If this plug is not mentioned in the rescue data sheet, the plug is not necessary for the high-voltage deactivation, or not designed as a rescue separation for rescue forces.

For some vehicles it may be sufficient to switch off the ignition and to disconnect the 12 V battery in order to deactivate also the high-voltage system.

However, if the vehicle is equipped with a direct current converter (DC/DC), supporting or supplying the 12 V system from the high-voltage system, only switching off the ignition and disconnecting the 12 V battery/batteries is insufficient for deactivating the high-voltage system and the 12 V system. In this case, the high-voltage system of such a vehicle can be switched off with one of the additional high-voltage deactivation possibilities.

The images show the operation of the Service-Disconnect. First the lever is pulled, then turned up and pulled out.

Step 1:

- ▶ Pull lever



r001_083

Step 2:

- ▶ Turn lever up and pull out plug



r001_084



If the Service-Disconnect plug is designed to be used by the rescue forces for deactivating the high-voltage system, this is marked in the rescue data sheet, as shown in the image.

High-voltage rescue separation point plug

Another design of the device for deactivating the high-voltage systems is shown in the image. The plug has a green casing and a tab for unlocking. A yellow label at the plug cable clearly indicates that this plug is rescue separation point.

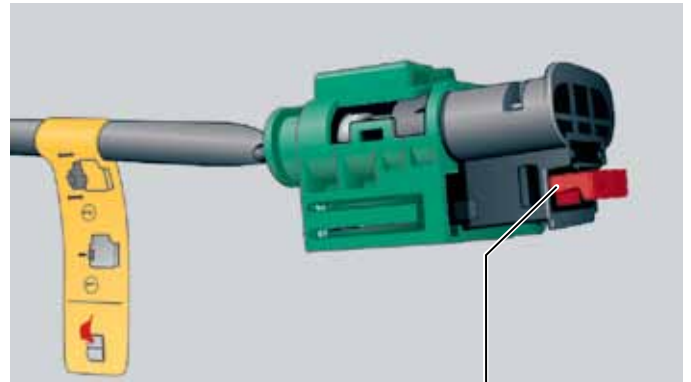

High-voltage rescue separation point plug

Tab

r001_047

The plug can be installed in different positions on the vehicle, as e. g. in the engine compartment. It is marked with the symbol "High-voltage rescue separation point" in the rescue data sheet.



Symbol "High-voltage rescue separation point" in the rescue data sheet



Example – Installation position in the engine compartment

r001_050

For unlatching the high-voltage rescue separation point plug, the red tab at the plug must be pulled out first.

After that, the red tab must be pressed and simultaneously the black plug must be pulled out completely from the green plug casing until it latches.



r001_089



r001_090

Label at the high-voltage rescue separation point plug for explaining the actuation of the high-voltage interruption at the high-voltage rescue separation point plug.

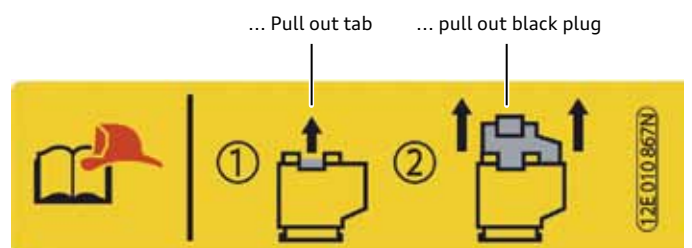

r001_052

Fuse

In order to offer an additional possibility for deactivating the high-voltage system, some hybrid and electric vehicles have a fuse in the fuse box specially marked with a label for rescue forces.



Symbol "Fuse box with fuse for high-voltage deactivation" in the rescue data sheet

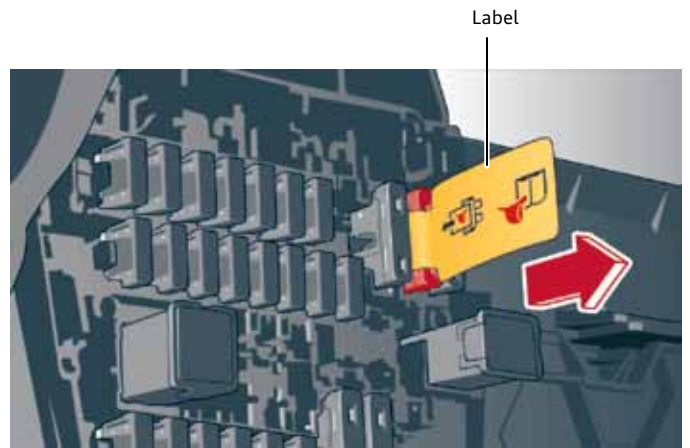

r001_053

Fuse box with a fuse marked with a (yellow) label for deactivating the high-voltage system

The fuse can be simply pulled out in order to deactivate the high-voltage system. The fuse box equipped with this fuse is identified in the rescue data sheet with an orange coloured fuse symbol "Fuse box with fuse for high-voltage deactivation". Moreover, the rescue data sheet in this case often includes further information about the exact location and the access to the fuse box.

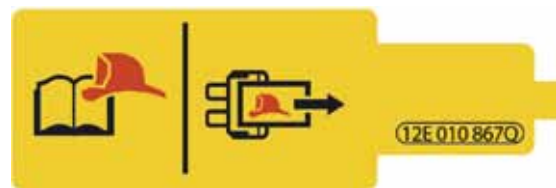

r001_091

Label at the fuse for deactivating the high-voltage system

Separation of the 12 V battery/batteries

The position of the 12 V battery/batteries can be taken from the rescue data sheet. If the battery is to be disconnected completely, disconnect the earth/minus pole first, then the plus pole.

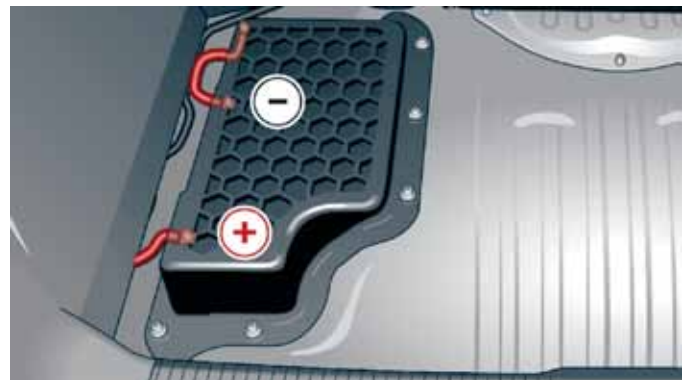

r001_099

Vehicle fire

Fires of hybrid and electric vehicles must be extinguished with water. Additions (e. g. foaming agents) can be used.

Further appropriate extinguishing agents are foam, CO₂ and extinguishing powder.

Take care to use appropriate personal protective equipment (e. g. compressed air breathing apparatus, fire-fighting garments etc.).

Vehicle under water

If a hybrid or electric vehicle should be under water, there is normally no danger of live car body parts.

After recovering the vehicle from the water, the rescue forces should drain the water out of the interior.

Subsequently, works on the vehicle can be performed taking into account the mentioned notes for the rescue work.

Natural gas drive (g-tron)



Vehicle identification – Natural gas vehicles

In most cases, the exterior of natural gas vehicles does not differ from conventionally driven models.

A type designation at the vehicle rear or at the mudguard may be an indication for a natural gas vehicle. Audi uses the logotype "g-tron" for natural gas vehicles, other car manufacturers use "NGT", "TGI", "Natural Power" etc.

If the vehicle does not have a type designation, other characteristics may also point to a vehicle with natural gas system.

For the Audi A3 Sportback "g-tron" these are, for example:

- ▶ Natural gas tank nozzle
- ▶ Fuel indicator in the instrument cluster
- ▶ Indications or logotype in the instrument cluster

The non-existence of these signs however is not a clear indication that the vehicle does not have a natural gas system. The logotypes can partially be cancelled in the orders; it is also possible that the vehicle owners remove them.

Distinguishing characteristics – natural gas vehicles

Type designation "g-tron" at the vehicle rear



r001_029



Open fuel filler flap with additional natural gas tank nozzle

Natural gas tank nozzle

r001_028

Fuel indicator and logotype in the instrument cluster



r001_070



Logotype on the design cover in the engine compartment

r001_049

Technical fundamentals

Introduction

The combustion engine of Audi natural gas vehicles can be operated with natural gas or with petrol. The primary drive uses natural gas, the petrol tank is a reserve.

Handling natural gas vehicles is generally not more dangerous than handling petrol or diesel vehicles; however, it differs in some items. Knowledge about these differences can be important for the rescue work after car accidents.



Natural gas (CNG – Compressed Natural Gas) must not be confused with liquid gas (LPG – Liquefied Petroleum Gas). Liquid gas and liquid gas installations differ fundamentally from natural gas and natural gas installations

Audi A3 Sportback g-tron as example for a natural gas vehicle

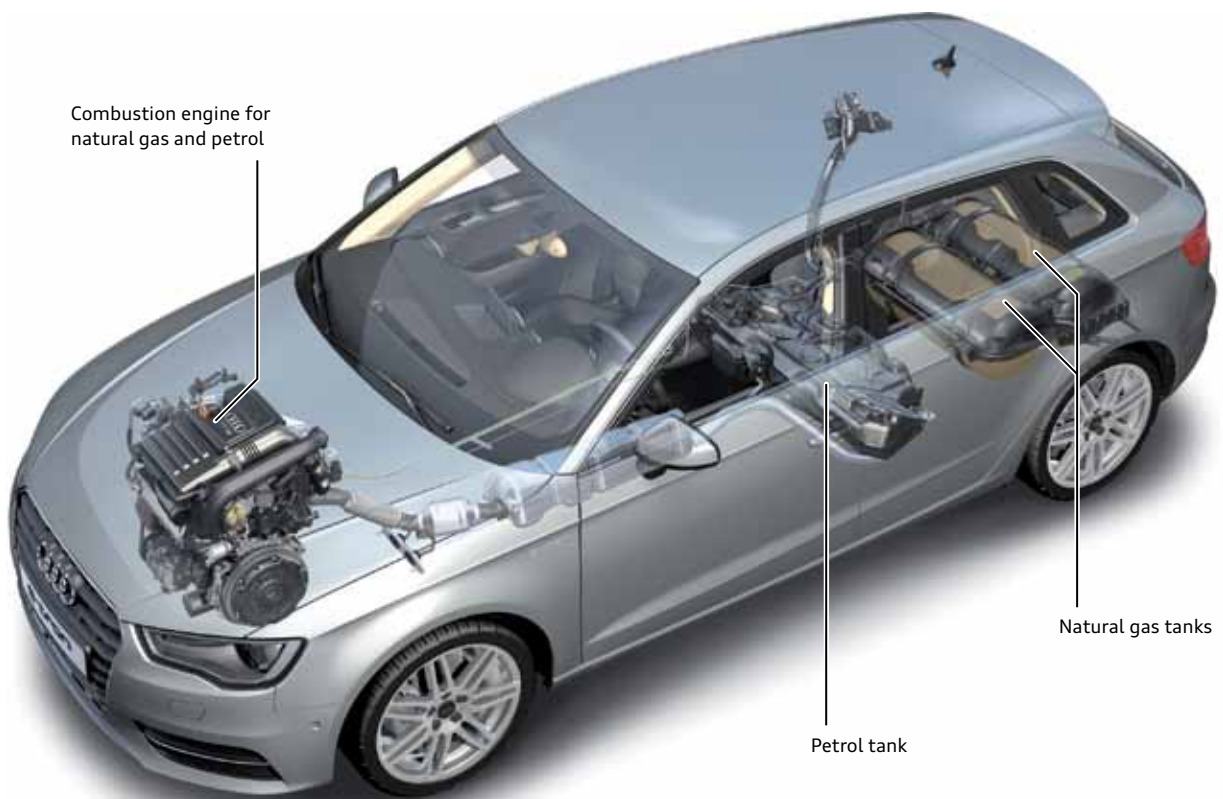

r001_026

Natural gas as a medium

Physical properties of natural gas

- ▶ Natural gas is a colourless, flammable gas (fire class C) which is odourless in original condition.
- ▶ For the use in vehicle it is odorized, i. e. an odorant is added to the gas. Thus, a natural gas leak can be detected already before the lower explosion limit is reached.
- ▶ Natural gas is lighter than air (density ratio natural gas/air approx. 0,6) and is thus very volatile in the open!
- ▶ Explosion range between 4 volume % and 17 volume %
- ▶ Ignition temperature approx. 640 °C

Audi A3 Sportback g-tron – Overview of natural gas components

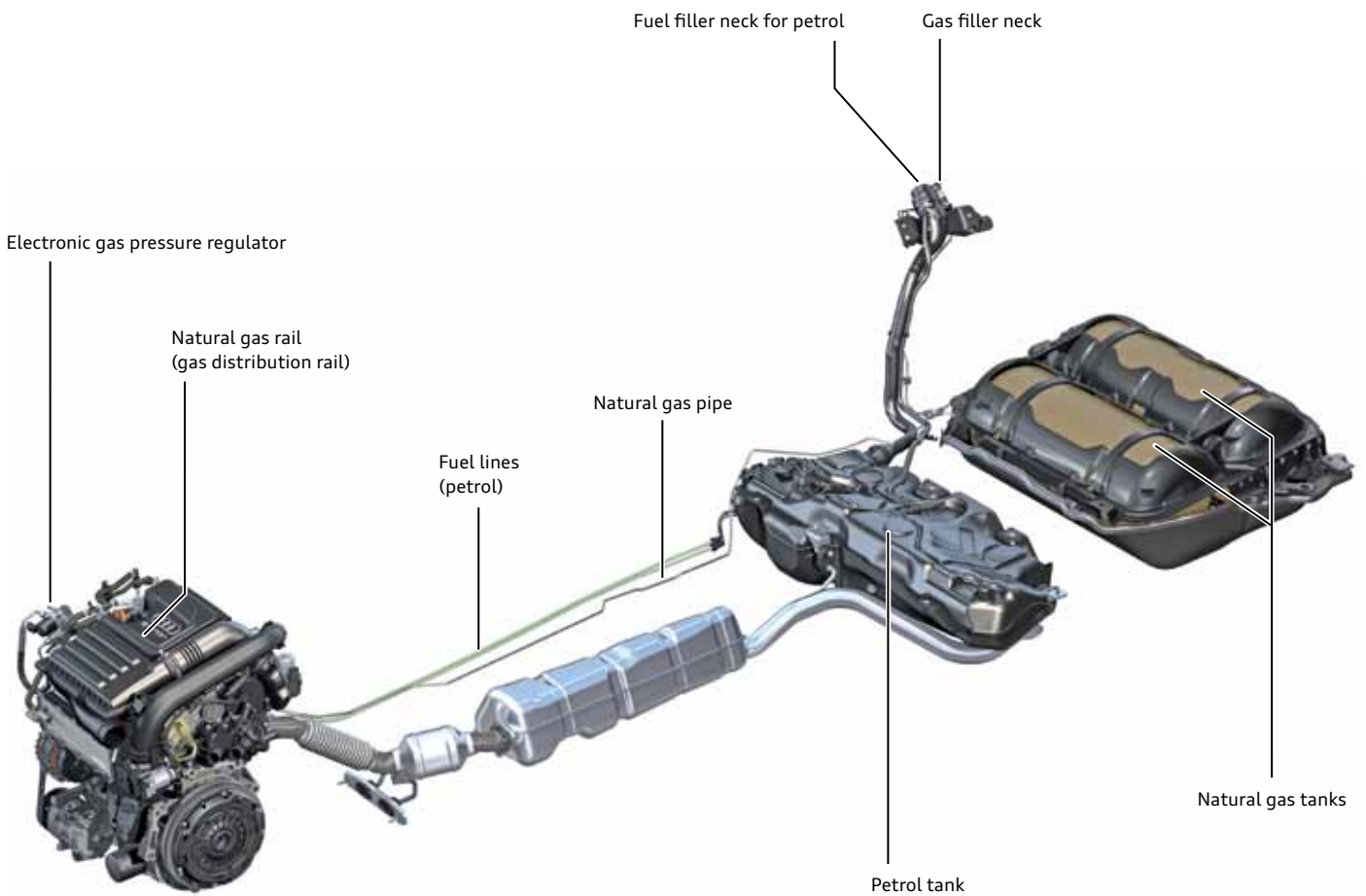

r001_100

Natural gas technology - "g-tron"

Schematic view of the natural gas system

A natural gas system consists of a high pressure part and a low pressure part. The system pressure in the high pressure part is 200 bar, and in the low pressure part approx. 6 – 9 bar.

The gas filler neck and the natural gas tanks with the tank shutter valves are located in the vehicle rear. The gas tubes are installed to the vehicle bottom towards the electronic gas pressure regulator in the engine compartment.

From the electronic gas pressure regulator the natural gas is transferred to the natural gas rail from where it is blown into the engine via injector valves.

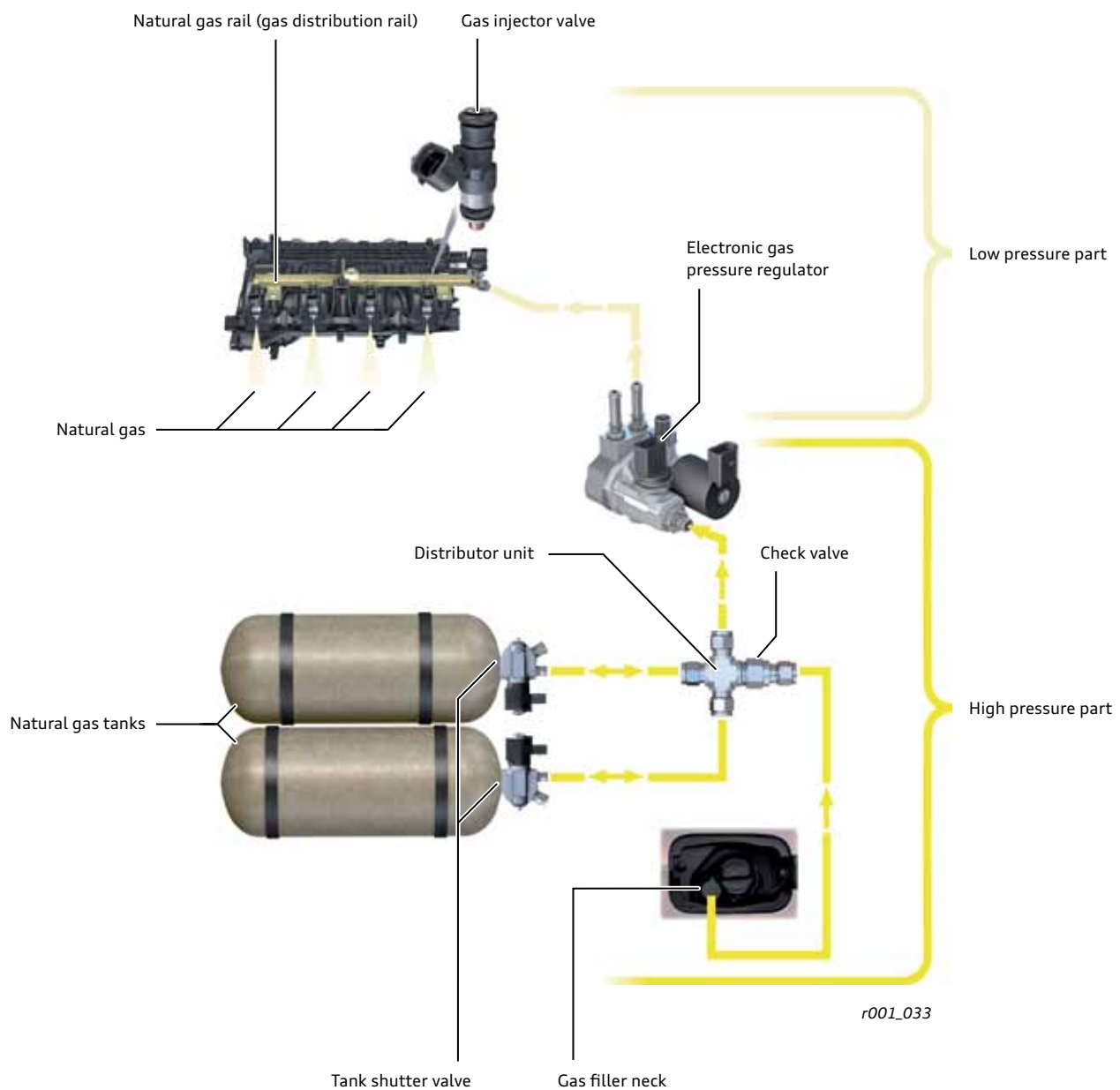

Natural gas tanks

The two natural gas tanks of the Audi A3 Sportback g-tron are installed at the bottom in the vehicle rear. They are fixed with tensioning belts to a carrier screwed to the car body.

During filling and emptying, but also due to temperature variations, the diameter of the natural gas tanks can change by a maximum of 2 mm. A protective layer is positioned between carrier, tensioning belts and natural gas tanks in order to avoid damage caused by expansion and retraction.



Tensioning belt with protective layer Natural gas tanks

Structure

The natural gas tanks are made of layered combined plastics.

Layer structure:

- ▶ Interior – layer of gas-tight polyamide
- ▶ Intermediate – layer of carbon fibre reinforced plastics (CFRP)
- ▶ Exterior – layer of glass fibre reinforced plastics (GRP) (serving after all for robustness and protection against damage)

The binding agent for the used fibre materials is high-strength epoxy resin.

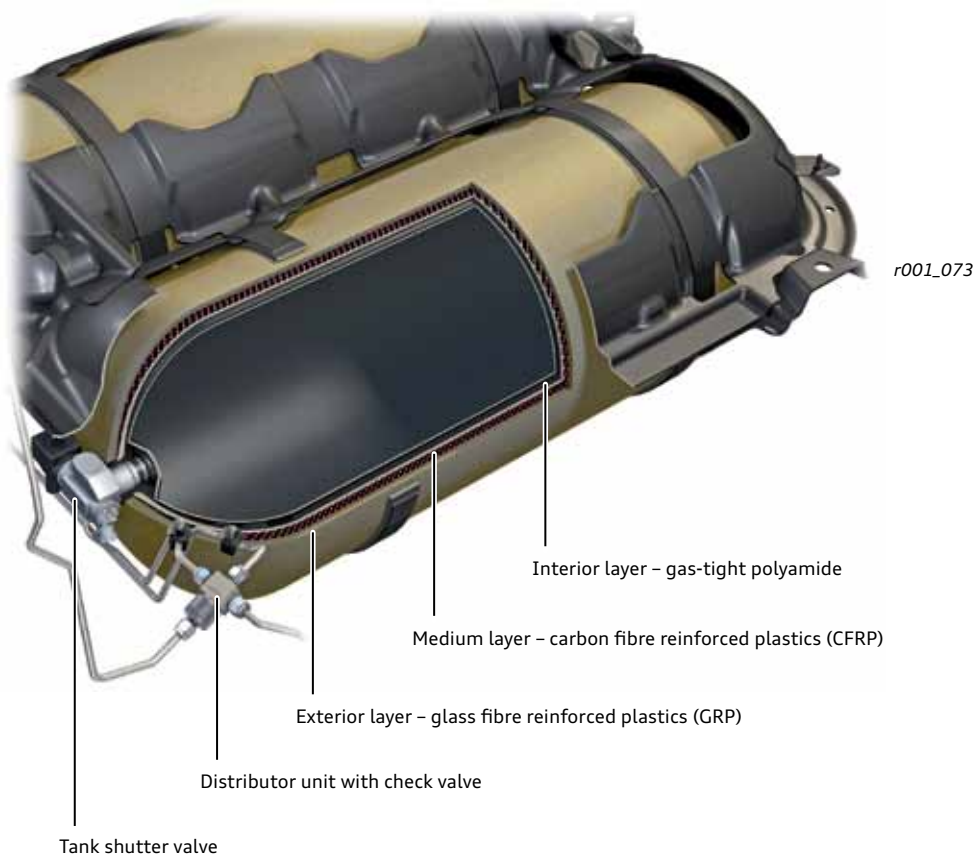

Safety devices

The natural gas installation is built in a way that it is protected against damage. The gas tanks are stable and heat-resistant. The high pressure lines are installed outside the passenger compartment.

The natural gas components are quipped with different safety devices. Natural gas vehicles generally have the same degree of safety as conventionally driven vehicles.

Cylinder valve

Apart from the valves for tank shutting, the cylinder valves have an integrated thermal fuse, a flow rate limiter as well as a manual shut-off valve.

If is necessary to shut off the gas tanks for rescue work, each gas tank must be shut off separately.

The manual shut-off valve can be shut with an open-end wrench or a ring wrench No. 5, at the square, by turning clockwise to the stop.

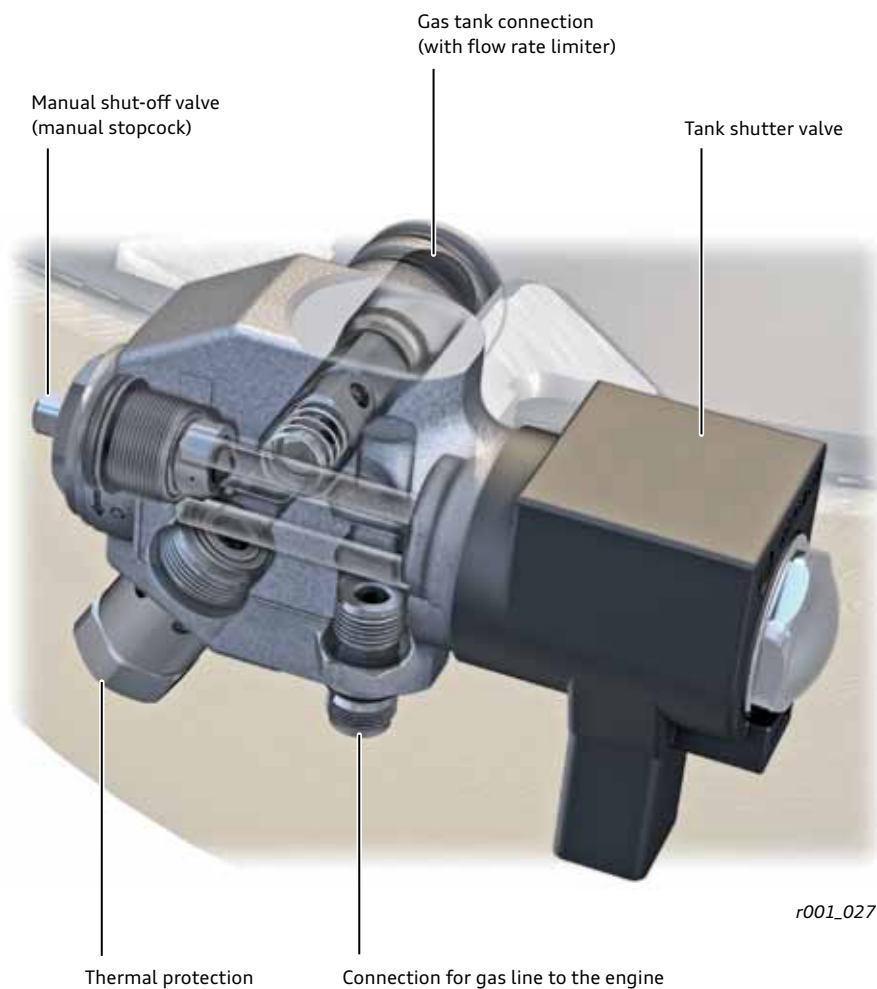

Tank shutter valve

The tank shutter valve is an electromagnetic valve which is opened during natural gas operation by the engine control unit. The valve closes automatically when the motor is shut off, during petrol operation, in case of a loss of voltage supply, as well as in a crash with airbag or belt tensioner activation.

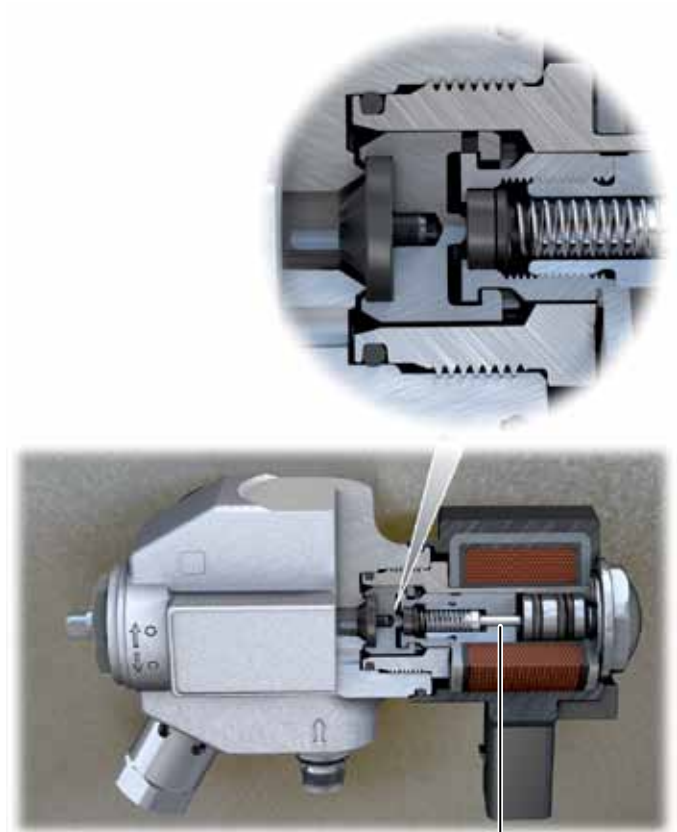

r001_074

Tank shutter valve
(electromagnetic)

Flow rate limiter

In case of a possible damage of lines or of the gas pressure regulator, the flow rate limiter reduces an uncontrolled outflow of gas. The flow rate limiter reduces leakage to a max. of 0.05 Nm³/min at 100 bar, i. e. a small residual leakage remains. The fuel outflow can be completely stopped at cylinder valves with manual shut-off valve (manual stopcock) by closing the manual shut-off valve.

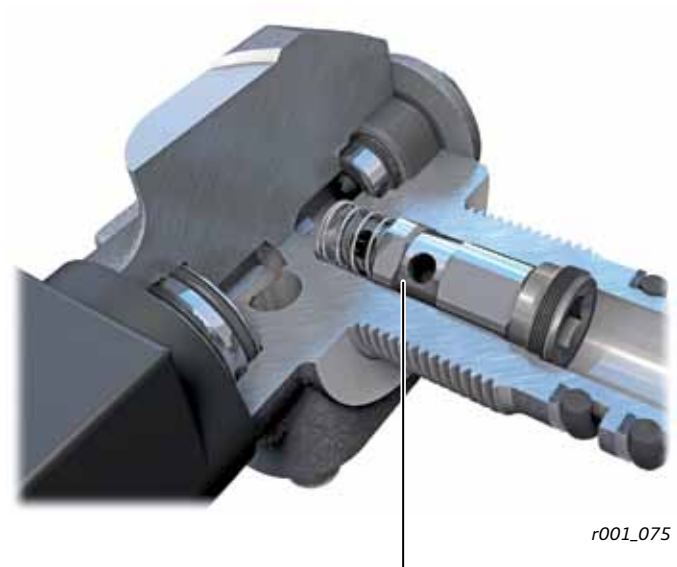

r001_075

Flow rate limiter

Thermal fuse

The thermal fuse prevents the natural gas tank from exploding due to excessive pressures at high temperatures.

In case of normal temperatures the thermal fuse closes the opening to the outside air.

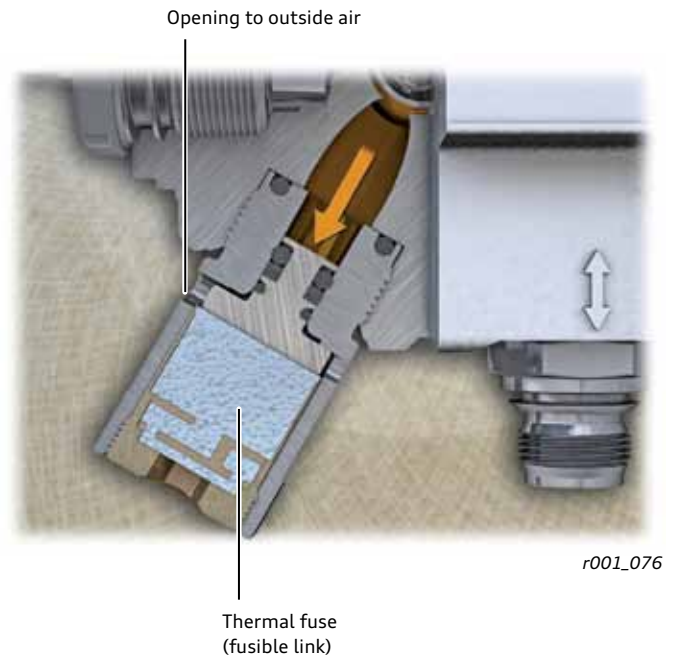

If the thermal fuse is heated to a temperature of more than 110 °C or a determined period of time, the fusible link melts and the opening to outside air is released.

Now the natural gas from the gas tank is released in a restricted way into the atmosphere (blow-off), ignites if a source of ignition is present, and then burns off. The release cannot be interrupted due to systemic causes, i. e. the tank will be almost completely emptied in any case.

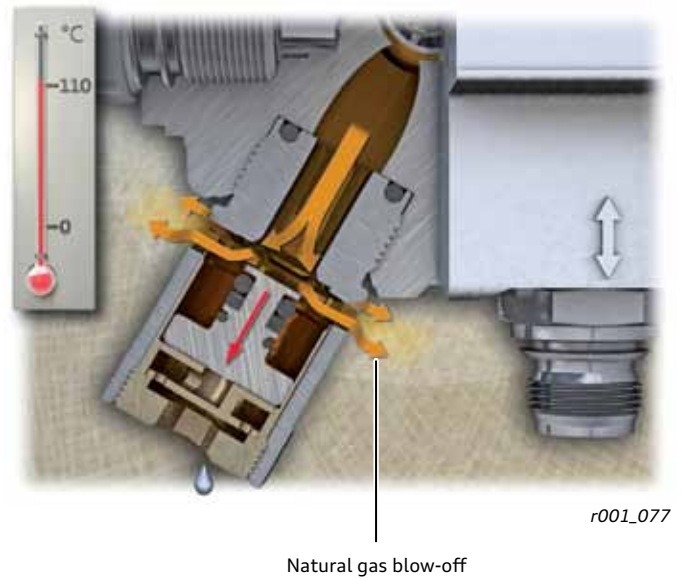

Natural gas blow-off

Manual shut-off valve (manual stopcock)

The natural gas tank can be closed manually with commercially available tools at the manual shut-off valve – see also information text to "Cylinder valve" (page 33).

For safety reasons, the connection to the blow-off channel of the thermal fuse is open even if the manual shut-off valve is closed.

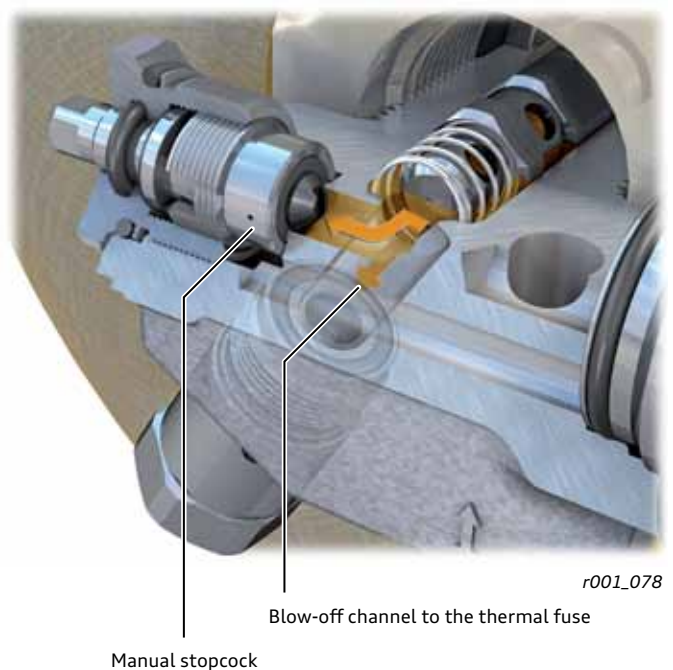

Notes for the rescue work

Handling natural gas vehicles is generally not more dangerous than handling petrol or diesel vehicles; however, it differs in some items.

Knowledge about these differences can be important for the rescue work after car accidents.

Technical assistance

The safety concept, in particular the type of installation of the natural gas tanks and associated components, and e. g. the regulation of the gas pressure for avoiding inadmissible overpressure in the gas system, generally ensures that no special or additional danger is posed by the natural gas system.

When handling natural gas vehicles, the procedures of rescue forces are generally regulated by corresponding laws, regulations or guidelines.

The subsequent chapters generally highlight issues which could become significant during the technical assistance after accidents of vehicles with natural gas drive.

Rescue data sheets

Vehicle specific peculiarities are described in the rescue data sheets.



The rescue data sheets for vehicles with natural gas drive may contain additional information about the handling the vehicle. In particular, the procedure for the deactivation of vehicle can be taken from the rescue data sheets of these vehicles in most cases.

Apart from the indications normally included in the rescue data sheets of conventionally driven vehicles, the rescue data sheets for natural gas vehicles indicate the position of the natural gas pressure tanks and the tank safety valves.

In addition to schematic top and lateral view (on the first page) rescue data sheets may include further pages with the following sections:

- ▶ Access to the natural gas tanks
- ▶ Localisation of manual stopcocks
- ▶ Manual closing of gas tank

The symbols in the rescue data sheets applying in particular for natural gas vehicles are:

Symbol	Designation	Symbol	Designation
	Natural gas pressure tank		Tank safety valve



The example on the following page shows the overall structure of rescue data sheet.

Example for a rescue data sheet

Sheet 1 and 2 of the rescue data sheet
for the Audi A3 Sportback g-tron (status 05/14)

Sheet 1

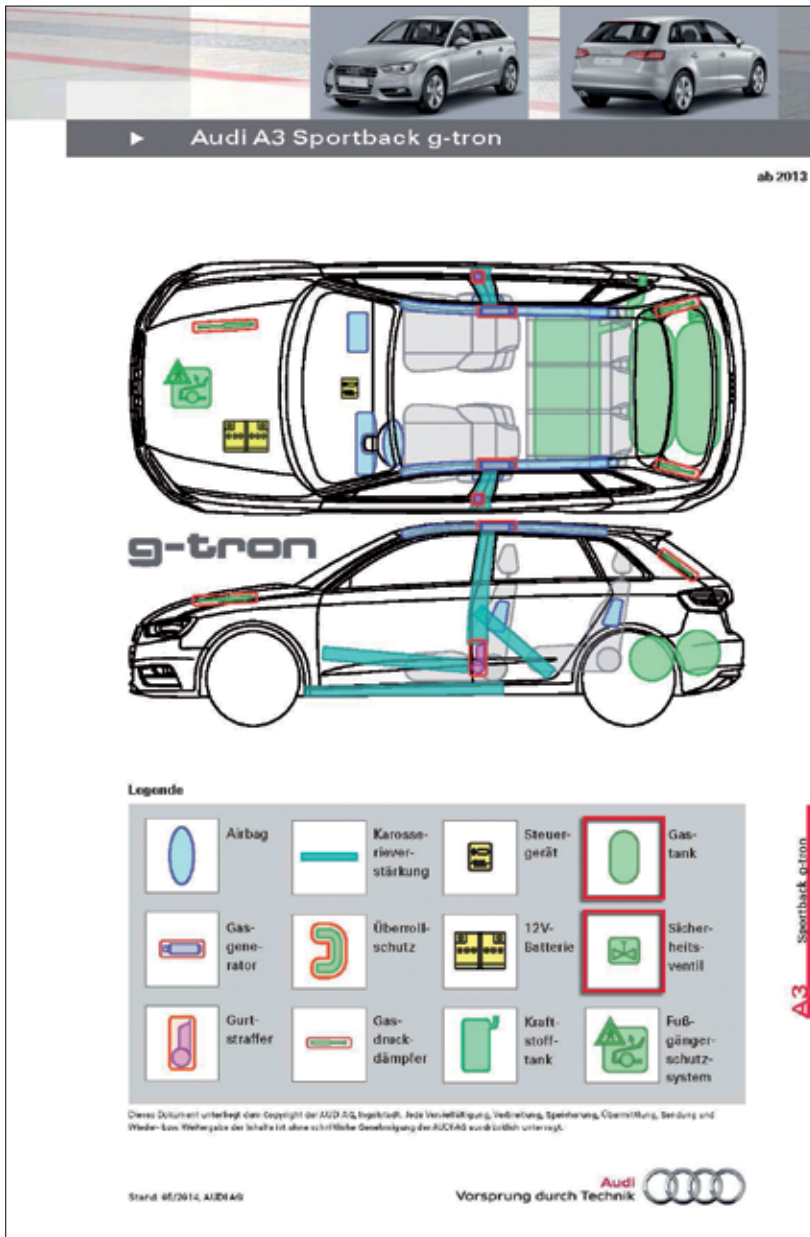

r001_031_1

Sheet 2



r001_031_2

 Symbols applying in particular for natural gas vehicles

The rescue data sheets for Audi vehicles can be downloaded on the Audi homepage website under:
<http://www.audi.de/rettungsleitfaden>

An overview of the sources of supply for rescue data sheets all vehicle manufacturers can be found on the website of the German Association of the Automotive Industry (Verband der Automobilindustrie e. V.) (VDA):
http://www.vda.de/de/arbeitsgebiete/rettungsleitfaeden_feuerwehr/

Vehicle accident or gas outflow in case of a natural gas vehicle

General approach

The following measures should be taken generally after an accident (the same as for all vehicles of the Audi AG)

- ▶ Switch off the ignition
- ▶ Disconnect the battery/batteries
- ▶ Disconnect the trailer power supply



In case of a critical gas concentration (>20 % LEL), do not disconnect the battery.

Procedure in case of leaking natural gas

If leaking natural gas is detected at the place of the accident (e.g. due to the smell of gas), the following measures should be taken:

- ▶ Switch off the engine
- ▶ Switch off the ignition
- ▶ Clear and cordon off the danger zone
- ▶ Do not start the vehicle; if necessary, remove from closed premises by pushing
- ▶ Ventilate the vehicle interior (open doors, windows, engine hood and luggage compartment)
- ▶ Determine gas concentration, observe accumulations in cavities, allow cross ventilation if necessary; disperse natural gas with fan; avoid sources of ignition.

Vehicle fire

In case of a burning vehicle, when also the natural gas tanks heat up considerably, the thermal fuses activate at approx. 110 °C, and a defined blow-off, ignition and burning of the natural gas occurs.

The blow-off of a full natural gas tanks lasts approx. 90 seconds until complete emptying.

Vehicles can be equipped with one or more gas tanks. The point in time when and which tank blows off or flares, cannot be determined exactly.

If no other dangers are present as e. g. spreading of the fire to other objects etc., the controlled burning of the vehicle must be taken into account if natural gas blows off and flares.

As soon as the blow-off of natural gas has ended, conventional fire-fighting can be started.

If the natural gas tanks are not affected by the fire (e. g. in case of a fire in the engine compartment), conventional fire-fighting can be started, too.



If the vehicle lies on the side or on the roof, a shooting flame must be expected when the overpressure protection trips. If the vehicle stands on its wheels, the gas flow is guided in vertical direction to the ground below the gas tank. A safety distance must be kept to the vehicle. The vehicle must be approached from the front with an angle, if possible.



If possible, the gas tank must be cooled with water, from a safe place, in order to avoid heating to a temperature where the overpressure protection trips. Tank cooling must be continued even of the overpressure protection trips.



The tripping of an overpressure protection can be recognised by a loud blow-off noise (hissing)!

